

GASKETS FOR PRECAST FORMS

PVC / RUBBER

gaskets for industrial precast forms

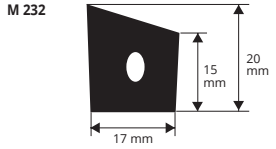

PVC / RUBBER
length rolls 50 lm

Article	
M 232	*

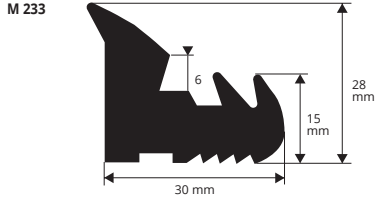
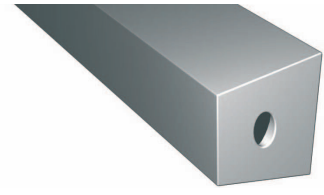

PVC / RUBBER
length rolls 50 lm

Article	
M 233	*

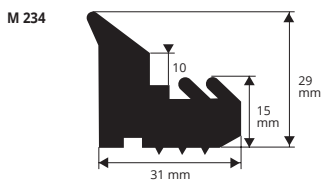
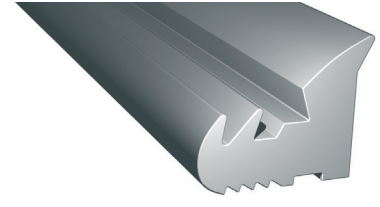

PVC / RUBBER - weight 650 g / lm
length rolls 50 lm

Article	
M 234	*
M 234 A	*
M 234 B	*

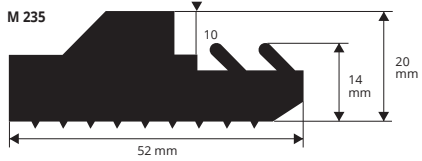
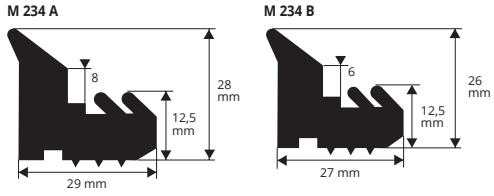
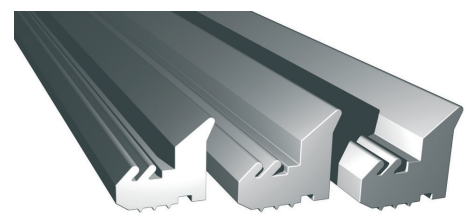

PVC / RUBBER - weight 980 g / lm
length rolls 50 lm

Article	
M 235	*

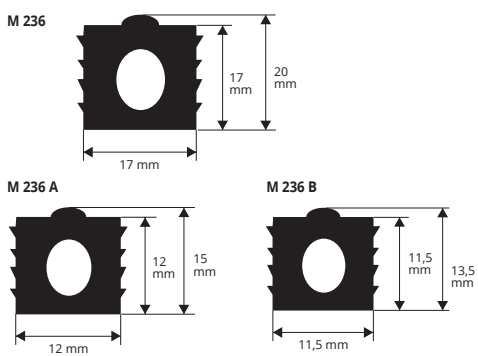
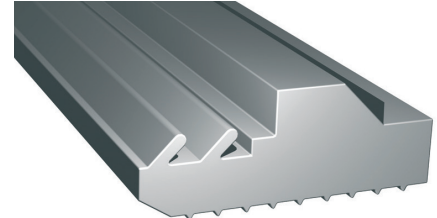

PVC / RUBBER - weight 270 g / lm
length rolls 50 lm

Article	
M 236	*
M 236 A	*
M 236 B	*

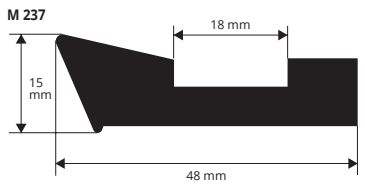
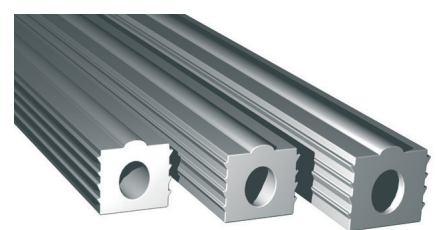

PVC / RUBBER - weight 510 g / lm
length rolls 50 lm

Article	
M 237	*

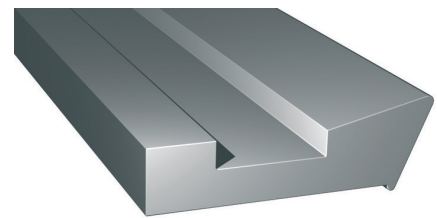

* = Production on demand with minimum quantity of 50 lm. Production delay 4/5 weeks. Price to be agreed.

GASKETS FOR PRECAST FORMS

PVC / RUBBER

gaskets for industrial precast forms

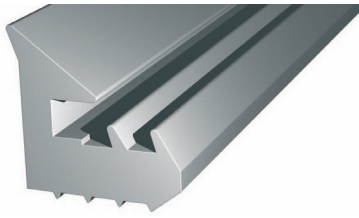

PVC / RUBBER - weight 695 g / lm
length rolls 50 lm

Article	
M 238	*

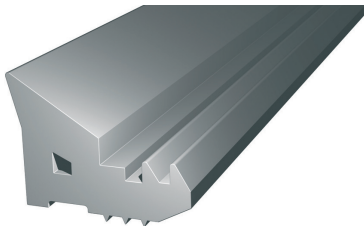
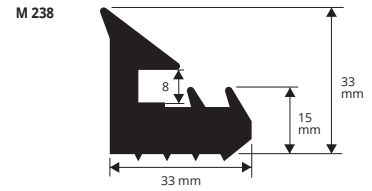

PVC / RUBBER - weight 880 g / lm
length rolls 50 lm

Article	
M 239	*

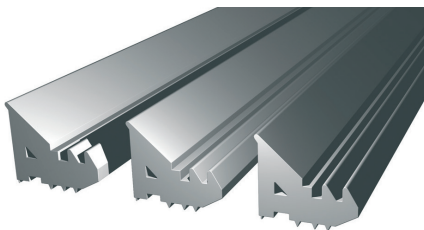
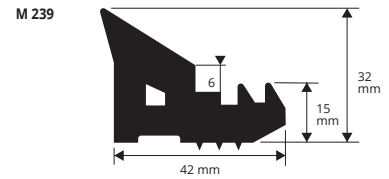

PVC / RUBBER
length rolls 50 lm

Article	
M 240	*
M 240 A	*
M 240 B	*

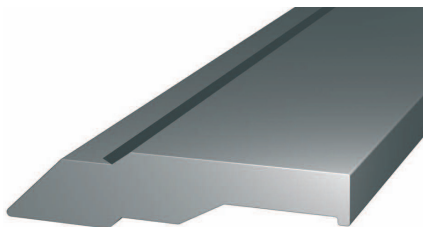
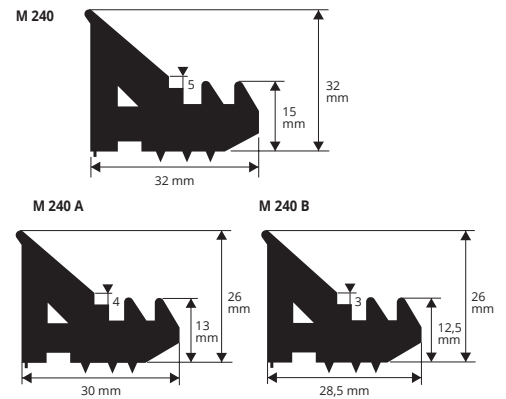

PVC / RUBBER
length rolls 50 lm

Article	
M 241	*

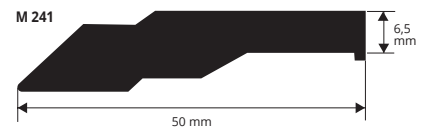

PVC / RUBBER - weight 695 g / lm
length rolls 50 lm

Article	
M 242	*

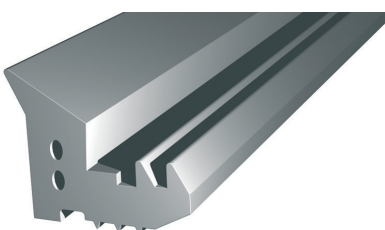
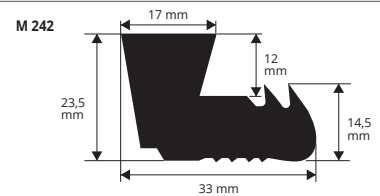

PVC / RUBBER - weight 630 g / lm
length rolls 50 lm

Article	
M 243	*

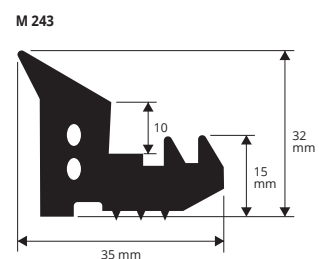

* = Production on demand with minimum quantity of 50 lm. Production delay 4/5 weeks. Price to be agreed.

GASKETS FOR PRECAST FORMS

PVC / RUBBER

gaskets for industrial precast forms

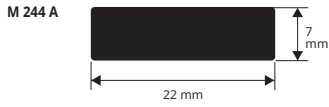
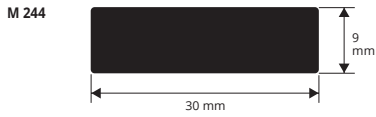

PVC / RUBBER - weight 180-330 g / lm
length rolls 50 lm

Article	
M 244	*
M 244 A	*

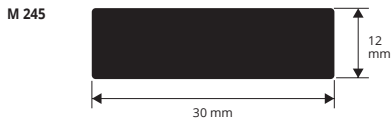
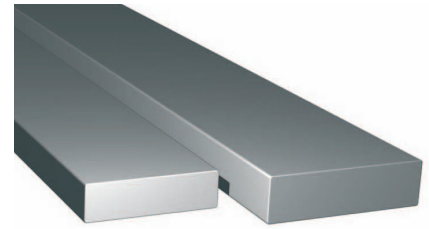

PVC / RUBBER
length rolls 50 lm

Article	
M 245	*

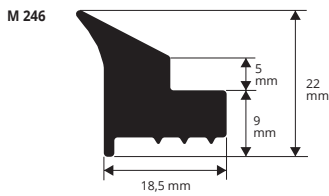
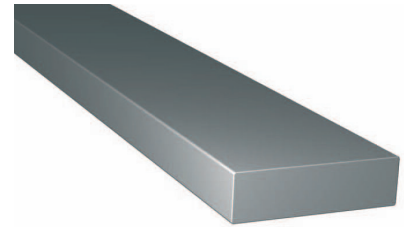

PVC / RUBBER - weight 330 g / lm
length rolls 50 lm

Article	
M 246	*

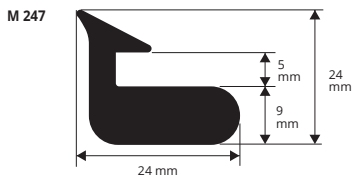
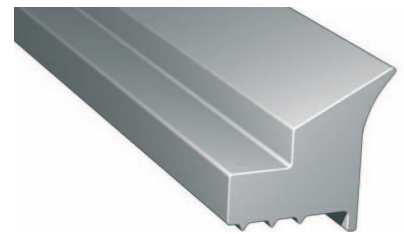

PVC / RUBBER - weight 335 g / lm
length rolls 50 lm

Article	
M 247	*

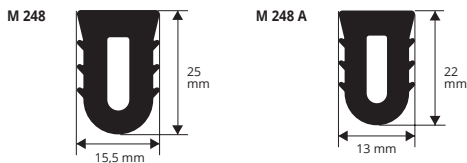
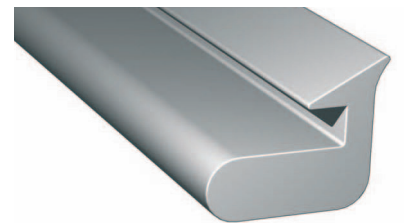

PVC / RUBBER - weight 270 g / lm
length rolls 50 lm

Article	
M 248	*
M 248 A	*

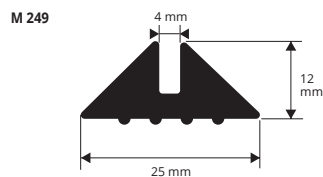

PVC / RUBBER - weight 220 g / lm
length rolls 50 lm

Article	
M 249	*



* = Production on demand with minimum quantity of 50 lm. Production delay 4/5 weeks. Price to be agreed.

GASKETS FOR PRECAST FORMS

PVC / RUBBER

gaskets for industrial precast forms



PVC / RUBBER
length rolls 50 lm

Article  *

M 250

M 250

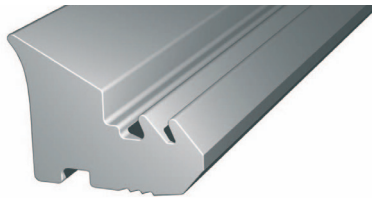
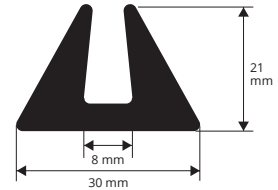

PVC / RUBBER
length rolls 50 lm

Article  *

M 251

M 251

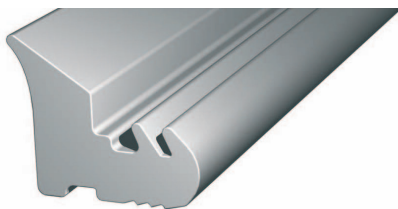
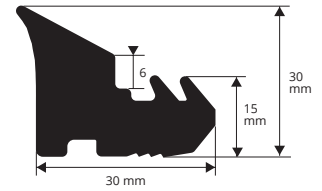

PVC / RUBBER
length rolls 50 lm

Article  *

M 252

M 252

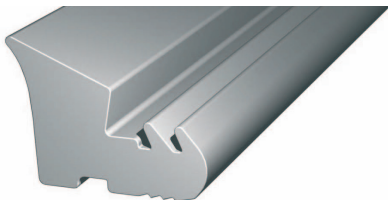
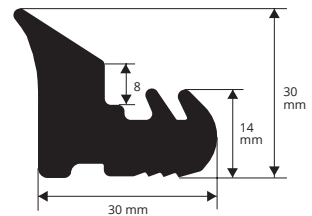

PVC / RUBBER
length rolls 50 lm

Article  *

M 253

M 253

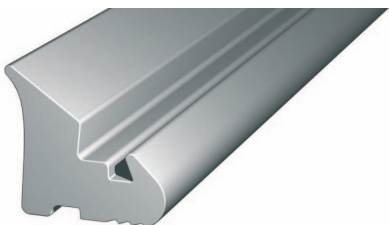
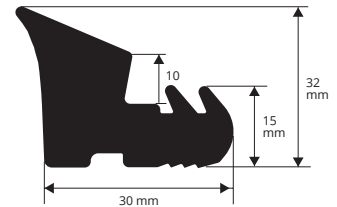

PVC / RUBBER
length rolls 50 lm

Article  *

M 254

M 254

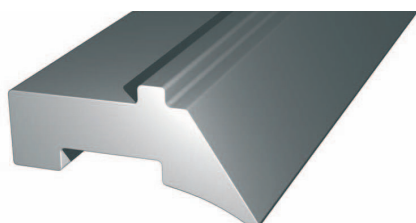
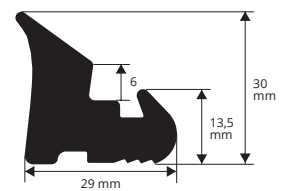

PVC / RUBBER
length rolls 50 lm

Article  *

M 255

M 255

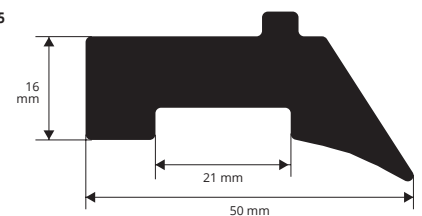

* = Production on demand with minimum quantity of 50 lm. Production delay 4/5 weeks. Price to be agreed.

GASKETS FOR PRECAST FORMS

PVC / RUBBER

gaskets for industrial precast forms

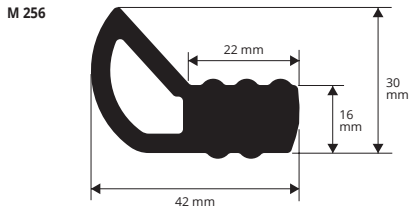

PVC / RUBBER
length rolls 50 lm

Article	
M 256	*

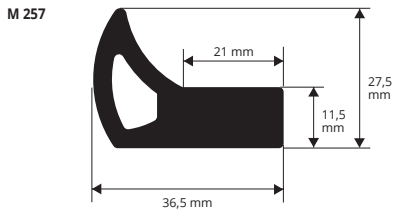
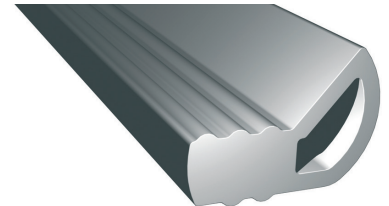

PVC / RUBBER
length rolls 50 lm

Article	
M 257	*

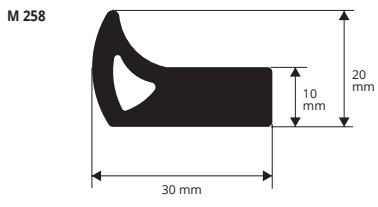
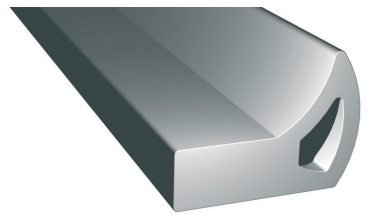

PVC / RUBBER
length rolls 50 lm

Article	
M 258	*

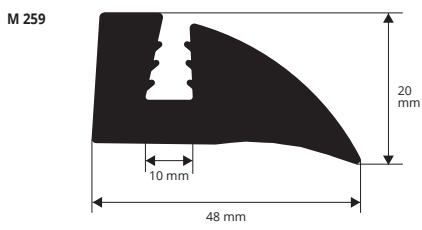
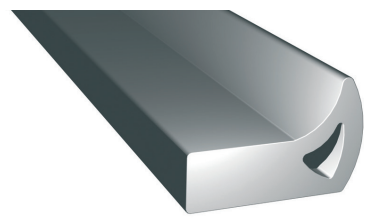

PVC / RUBBER - weight 750 g / lm
length rolls 50 lm

Article	
M 259	*

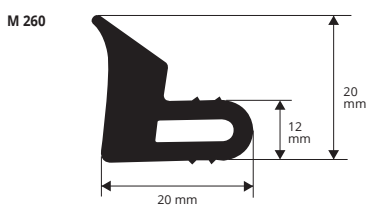
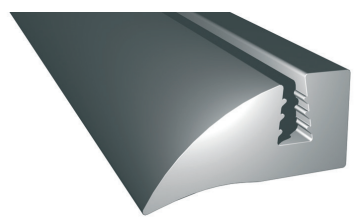

PVC / RUBBER - weight 350 g / lm
length rolls 50 lm

Article	
M 260	*

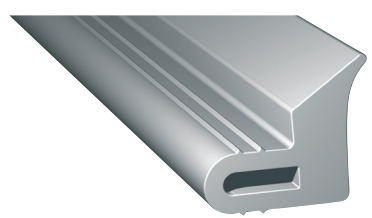

* = Production on demand with minimum quantity of 50 lm. Production delay 4/5 weeks. Price to be agreed.