

PROSTAIR

NATURAL ALUMINIUM
+ VINYL RESIN / RUBBER INSERT

PROSTAIR is a step nosing profile used to improve slip and slide resistance on the step, to protect ceramic steps and to prevent accidents. It consists of a rigid aluminium base and a changeable vinyl rubber insert available in various colours and widths. Compulsory in public environments to comply with EEC accident-prevention standards.

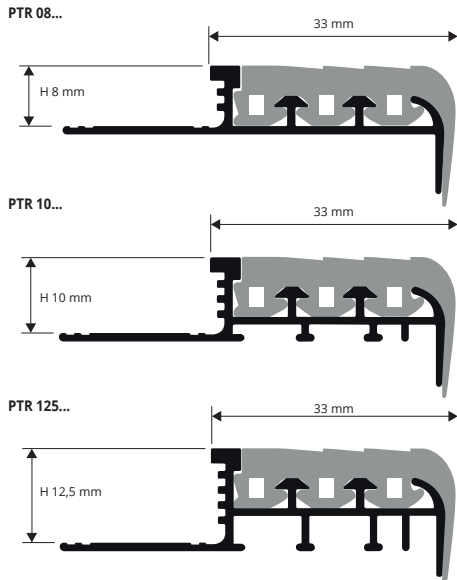

EXAMPLES AND INSTRUCTIONS FOR LAYING METHODS

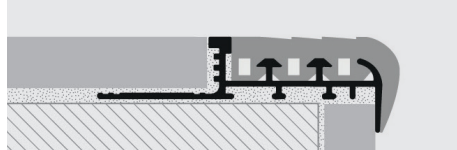

1. Choose the PROSTEP/PROSTAIR in the required width and colour according to the thickness of the tile. 2. First fix the riser part, placing it at the correct and final height. 3. Fill the empty spaces under the profile with the tile adhesive. 4. Apply the adhesive to the tread, lay the profile with the punched base fully sunk into the adhesive and align the profile so that its lip covers the edge of the riser tile. 5. Lay the tread tiles, aligning them so that they are flush with the upper and rear part of the profile.





INTERCHANGEABLE VINYL RESIN / RUBBER INSERT
bar length 2,7 lm - pack. 20 Pcs - 54 lm

Article		
PTGRA		
PTGRB		
PTGRN		
PTGRG		

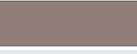
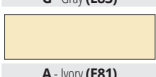

COLOURS

		
G - Gray (E83)	N - Black (E85)	B - Beige (E84)
		
A - Ivory (E81)		

NATURAL ALUMINIUM + VINYL RESIN / RUBBER INSERT
bar length 2,7 lm - pack. 10 Pcs - 27 lm

Article	H mm		
PTR 08...	8		
PTR 10...	10		
PTR 125...	12,5		

Available in the colours: G - N - B - A. The code of the selected colour must be added to the article code.
E.g.: PTR 08... (chosen colour grey) PTR 08G.

END CAP IN PVC - pack. 2 Pcs (1 R and 1 L)

Article	
TPT .../1	

Available in the colours: G - N - B - A.
E.g.: TPT G/1.
Articles not for sale singly

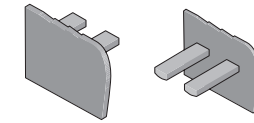

PROSTEP

RIGID VINYL RESIN
+ VINYL RESIN / RUBBER INSERT

PROSTEP is a step nosing profile used to improve slip and slide resistance on the step, to protect ceramic steps and to prevent accidents. It consists of a rigid base in high-strength vinyl resin and a changeable vinyl rubber insert available in various colours and widths. Compulsory in public environments to comply with EEC accident-prevention standards.

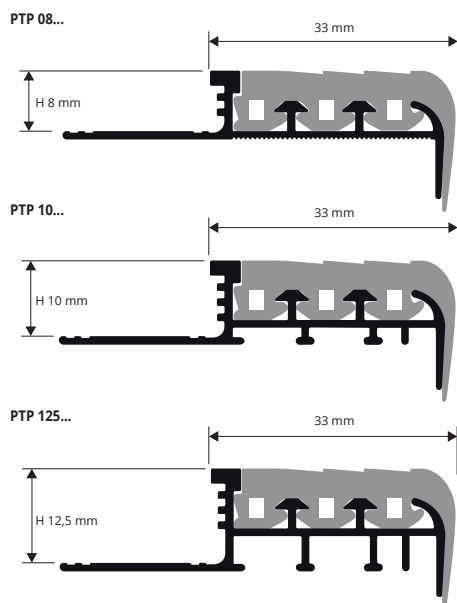

For instructions see the product above







INTERCHANGEABLE VINYL RESIN / RUBBER INSERT
bar length 2,7 lm - pack. 20 Pcs - 54 lm

Article		
PTGRA		
PTGRB		
PTGRN		
PTGRG		



COLOURS

			
G - Gray (E83)	N - Black (E85)	B - Beige (E84)	A - Ivory (E81)

IMPACT PROOF VINYL RESIN + VINYL RESIN / RUBBER INSERT
bar length 2,7 lm - pack. 10 Pcs - 27 lm (PTP 08... - 54 lm)

Article	H mm		
PTP 08...	8		
PTP 10...	10		
PTP 125...	12,5		

Available in the colours: G - N - B - A. The code of the selected colour must be added to the article code.
E.g.: PTP 08... (chosen colour grey) PTP 08G.

END CAP IN PVC - pack. 2 Pcs (1 R and 1 L)

Article	
TPT .../1	

Available in the colours: G - N - B - A.
E.g.: TPT G/1.
Articles not for sale singly

